



The Solar-Power Alternative in Broadband Wireless Networks

A Primer on the Uses and Benefits of Solar Power in
Outdoor Broadband Wireless Networks

The Solar-Power Alternative in Broadband Wireless Networks

White Paper



A Primer on the Uses of and Benefits of Solar Power in Outdoor Broadband Wireless Networks

Why Solar Power?

There are many reasons why solar power is a good alternative to traditional power sources, for wireless networks:

- When deploying a wireless network, power isn't always where you need it and it is cheaper to install solar than it is to run a traditional power line
- Solar power is always on in times of emergency when traditional power may have gone down
- Solar pays for itself over time
- Solar is an alternative to fossil fuels which uses a renewable source in sunlight

In the world of technology one thing sits above all else: power. Electricity is needed to run everything from your toaster to your PDA. With this pervasive need throughout our society, access to electrical power is critical. Many methods of energy production exist including alternative energy sources.

Dictionary.com defines alternative energy as "energy, as solar, wind, or nuclear energy, that can replace or supplement traditional fossil-fuel sources, as coal, oil, and natural gas."

In this document we will be focusing on solar energy and how it pertains

to Outdoor Wireless Broadband, as well as how Proxim's line of products is a good choice for pairing with solar power systems.

Solar and wireless walk hand in hand as if they were made for each other because they both do something very important. They bring something to a location that normally would not be possible without a wire. For Solar energy it is power, for wireless it is data. It's no small coincidence that wireless systems need power, and the solar systems can provide it creating completely autonomous installations.

For Solar energy it is power, for wireless it is data. It's no small coincidence that wireless systems need power, and the solar systems can provide it creating completely autonomous installations.



Solar Power

Solar power is made possible with the use of Photovoltaic cells, or PV for short. Comprised of several layers of material, these cells are able to produce electrical power from exposure to sunlight. The most common has two layers of crystallized silicon called N-type and P-type. A reaction on an atomic level when exposed to light causes electrons to flow between the layers by way of metal contact plates and grids connecting the layers, and on the way through, an external load gets powered by the passing electrons. This is where the useable energy is gathered. The amount of usable energy is a direct result of how much light there is, as well as how big and how many PV cells are present.

There are many uses for solar power, ranging anywhere from powering handheld calculators, satellites in orbit, or even powering entire towns. A drive anywhere in the United States will cause you to encounter solar powered equipment. Highway departments use them for traffic monitoring – telemetry – all over the roadways. The use of Outdoor Wireless Broadband technology is continually increasing throughout the world. Along with it will always be the need for power, and there are three key things to consider when looking at solar power as an energy source for your wireless deployments.

Necessity

Outdoor Broadband Wireless requires as much line of sight as possible. Also, range restrictions and obstacles require that you place multiple Access Points (AP) in a given area. Often, the installation point of an AP that gives you the



best coverage may not have any power source, or may require modifications to existing power.

These include:

1. Installation points where power is not available such as rooftops with no egress point, locations without available light poles, open areas such as parks, etc.
2. Light poles that are only powered at night
3. Remote locations in rural, wilderness, or remote areas in developing countries where power has never been run
4. Power systems that are not compatible or only have hazardous voltages available that would require changes such as addition of large transformers etc.

There may also be many applications that require wireless data connectivity in times of emergency that are independent of power or require portability or rapid

temporary deployment of equipment.

1. Public safety or disaster recovery where permanent deployments are installed with solar to provide network connectivity in times of emergency and temporary communications points can be setup independent of vehicle power or a failed or damaged power grid.
2. Transportation service and maintenance already makes use of isolated caution and information signs powered with solar energy. Wireless stations can be powered the same way to provide data communications. This is especially beneficial for major projects that may include a satellite office location for an extended period of time.

All of this provides a practically unmatched level of flexibility in deployment allowing you to create all in one systems of radios and power source that can be mobile, provide temporary service, or be redeployed rapidly.

Environmental Impact

As an alternative energy source to fossil fuels solar power consumes a renewable energy source-sunlight. Additionally, production and utilization of solar power does not emit any greenhouse gases. These are compelling reasons for choosing solar power as an environmentally friendly method of powering your wireless network.

Economic Considerations

Since solar power uses a free renewable energy source there are no re-occurring costs from consuming power. Also, in many areas an installation on a pole will be subject to pole attachment & utility infrastructure costs. These are fees that are charged whether you actually use any power or not and are governed by State tariffs. All utilities such as the telephone company and cable operators making attachments to utility poles pay a uniform fee for attachment to a pole. Furthermore, by using solar power you can avoid the cost of actually running power lines to areas that don't have existing power. In some cases meters must be installed, thereby increasing costs. Connections to existing light pole timing systems could mean a lack of power during daylight hours. Battery charging systems may provide a solution to gang switched street lights. Solar power systems are installed once and require very little, if any, maintenance. Often, the cost to install solar is less than installing electrical power at a site.

Importance of Low Power Consumption

Industrial grade solar power systems include both a PV panel sized for the power needs of the application,

a charge controller and housing and a specialized battery to keep the system running when there is no light. The size and cost of the solar power system is directly affected by the following things:

1. The amount of power you will require on a daily basis, measured in amp-hrs/day
2. The amount of available sunlight per day based on insolation (amount of available sunlight per day) and temperature of the region throughout the year

The minimum level of power the Solar system can provide on the worst days for sunlight forecast is your threshold, and should not be below the amount of power required by your wireless equipment. In the Northern Hemisphere this typically occurs in late November and December when daylight periods are the shortest in duration. The lower the power consumption of your wireless equipment, the less power is required on a daily basis. This translates to a smaller and less expensive solar power system.

Solar Panel Size Considerations

The size of a solar panel array is determined by two things; the wattage and the voltage. Depending on your needs the array can get quite large. The smallest arrays will be 100w or below, and provide a 12v power system. The sizing of the system can be accommodated in the following manner:

1. The largest single panel is typically 100-120w. More wattage is achieved by combining multiple panels in parallel, e.g., two 100w panels in parallel make a 200w system. The voltage, however, does not increase; it will stay the same as if it were a single panel.
2. Each single panel puts out 12v, more than one are combined in series to increase the voltage, e.g., two 12v in series makes 24v. The wattage, however, does not increase; it will stay the same as if it were a single panel.

See Fig. 1.1, Solar Panel Sizes.

Fig. 1.1 Solar Panel Sizes

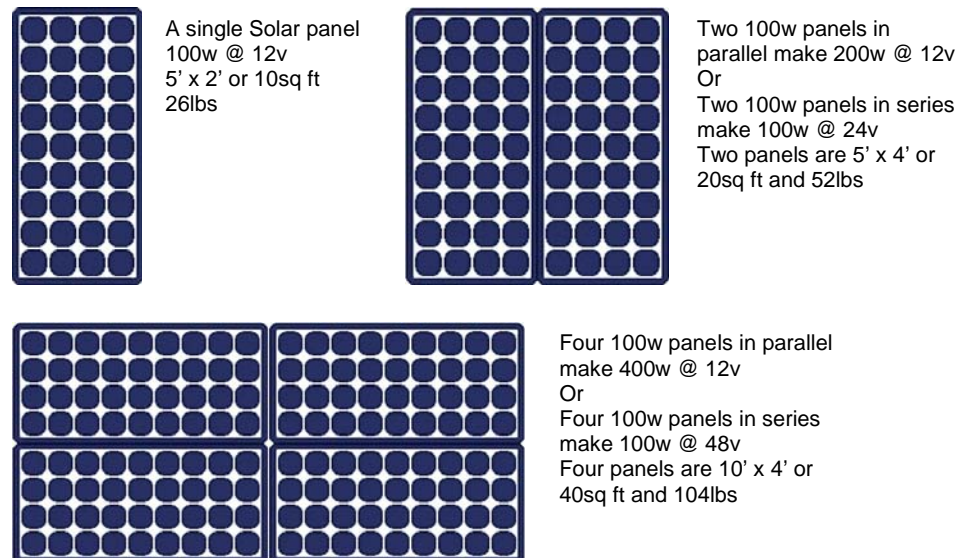

Proxim Wireless and Solar Power – A Winning Combination

Proxim Wireless provides a broad portfolio of Broadband Wireless products enabling end-to-end solutions that are feature rich, easy to deploy and use, support extensive security features, and have a low Total Cost of Ownership. But, most important, Proxim's portfolio includes products with the lowest power consumption in the industry.

1. Solutions which have higher power consumption require solar panels and battery systems twice, or even several times the larger, making the solution either cost prohibitive or size prohibitive.

2. These larger systems could pose installation problems based upon weight or space limits. The smaller the system, the more installation flexibility they can offer.

Today, more than ever, it is important to think green and choose environmentally friendly technologies. The flexibility of deployment with solar power, plus RoHS (Reduction of Hazardous Substances) compliance of the Proxim products we will be covering in this paper are compelling reasons to go this route. You aren't losing anything by being environmentally friendly; in fact you are gaining something that cannot be rivaled; an Outdoor Wireless Broadband system that is *truly wire free!*

Key Proxim Products for Outdoor Broadband Wireless

Proxim Wireless offers the industry's broadest portfolio for broadband wireless networks-Wi-Fi mesh, WiMAX, Wi-Fi and wireless

backhaul. No company is better equipped to address the need for scalable broadband wireless networks as enterprises and communities worldwide strive to unwire their broadband access and communications. Wi-Fi mesh and WiMAX are often deployed in tandem by service providers and municipalities since many mesh deployments require backhaul connectivity, which can be provided efficiently by WiMAX and a WiMAX deployment requires Wi-Fi mesh to provide access to the growing base of Wi-Fi enabled devices and multi mode Wi-Fi phones.

We will now briefly look at two key Proxim products used in a typical outdoor broadband wireless network – AP 4x00 MR-LR and Tsunami MP.11 5012 subscriber unit.

Proxim's award winning Tsunami MP.11 product portfolio consists of point to multipoint products. Reducing the cost barrier for broadband wireless access to any end-user, the Tsunami MP.11 5012 subscriber units offer an aggressive ROI for service providers and network operators.

Key features of the Tsunami MP.11 5012-SUR (outdoor subscriber unit):

- Operates in license-free frequency bands worldwide: versions available for 5.15-5.35 GHz, 5.47-5.725 GHz and 5.725-5.850 GHz
- Supports VLANs and fast roaming: enables traffic separation and mobility
- Scheduled media access controller (MAC), also known as polling: enables a base station to hear all subscriber units, preventing nodes from interfering with each other and increasing system throughput



Fig 1.2 Tsunami MP.11 5012 Outdoor Subscriber Unit Mounted on a Rooftop

- Orthogonal frequency division multiplexing (OFDM): enhances non-line-of-sight performance improving deployment in challenging areas
- Quality of Service (QoS): supports voice, video and data.
- RADIUS-based bandwidth management: deliver multiple service plans
- Asymmetric bandwidth management: increases service provider revenue through creation of uplink bandwidth tiers
- Outdoor enclosure with a built-in 18 dBi flat panel antenna
- Low power consumption of 3w average: ideal for alternate power sources like solar

The dual-radio ORiNOCO® Wi-Fi Mesh Access Points deliver video, voice and data over Wi-Fi to the edge of a network over a flexible, auto-forming, self-healing, near line of sight mesh backbone. The dual-radio architecture separates the mesh backbone traffic from the edge access traffic, increasing capacity compared to single-radio mesh architectures. ORiNOCO mesh

products are available for IEEE 802.11g and IEEE 802.11a simultaneous operation or IEEE 802.11g and 4.9 GHz public safety simultaneous operation.

Key features of ORiNOCO AP 4x00 are:

- Industry leading security and VLAN support
- Self-healing, self forming, intelligent mesh
- Dual radio architecture – one for mesh, the other for Wi-Fi access: maximizes spectrum usage
- Low power consumption of 7w average: ideal for alternate power sources like solar
- Support for 4.9GHz : enables public safety applications
- WMM/IEEE 802.11e draft QoS support: supports triple play applications

To calculate the size of the solar system (panel), one needs to understand the average power consumption of the unit. Table 1.1 provides a quick summary of the power requirements and corresponding solar panel for these Proxim products. Note that due to extremely low average power consumption of Proxim’s ORiNOCO mesh APs and Tsunami MP.11 outdoor subscriber units, the solar panel required is small and hence practical.

Fig 1.3 ORiNOCO AP 4x000 Outdoor Mesh Unit



Table 1.1 Key Power Characteristics of Indicated Proxim Products

	Current Draw*	Amp-hrs/day* 24hrs	Solar System Size***
AP-4000MR-LR	7w	15.4**	100w 10 sq ft panel
MP.11 5012-SUR	3w	6.6**	50w 5 sq ft panel

*Estimate
 **10% inefficiency factor added for DC/DC converters. Cheaper units with higher inefficiency will increase your amp-hrs/day, so always use units with the highest efficiency values.
 ***Estimate based upon a fixed 4.0 peak sun hours, localized changes in sun hours and temperature are not factored

Muni Network Example

Let’s look at an example deployment of a muni network. The purpose of this network is to provide Wi-Fi access to key city areas in downtown, south-east, and the business district, as indicated. Since this is an outdoor Wi-Fi network, coverage needs are based upon location and density of population at given times. Ubiquitous Wi-Fi coverage is not needed as there are many areas where Wi-Fi coverage simply does not make sense and would not end up being used, creating an unnecessary cost.

Careful planning in this regard will minimize waste while maximizing return. If situations change the independent nature of the installations allows for rapid and easy re-deployment, or new deployments when needed.

Here we have several Proxim AP-4000MR-LR mesh portals being backhauled to an Operations Center by a Tsunami MP.11 system. Proxim mesh AP’s are then placed through the city in strategic locations to provide coverage to key areas.

Fig 1.4 Schematic of Deployed Muni Network

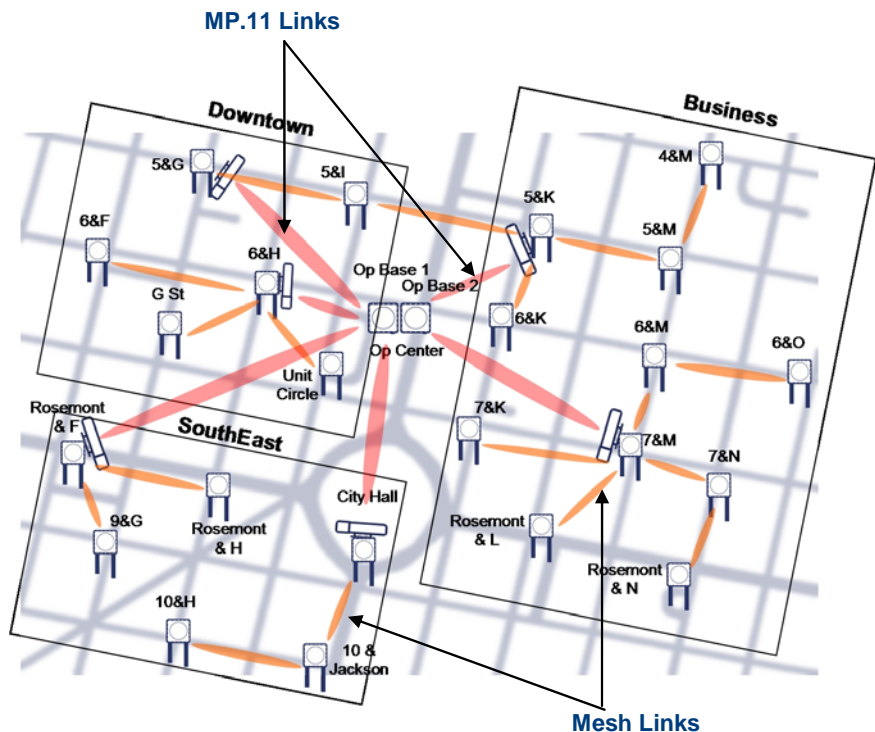

Muni Network Example Cont.

Six points throughout the city areas are chosen as good vantage points for the mesh portals. At each location a mesh portal is directly connected to a Tsunami MP.11 5012-SUR outdoor subscriber unit, which then backhauls the data from the mesh unit to the MP.11 base station at the Operations Center, linking the network together. The low power consumption of, both, the ORiNOCO AP-4000MR-LR and Tsunami MP.11 5012 allows for powering both from a single solar unit.

We will also assume that all install locations, with the exception of the Op Center, will be using solar power. This means the following things:

1. There will be 17 individual mesh AP's deployed requiring their own solar power systems.
2. There are 6 install locations that include both a mesh portal and a Tsunami MP.11 subscriber unit. These will require a larger solar power system, or two separate ones. For this example we will assume one large system to accommodate both units.

See Figure 1.5, Schematic of Deployed System.

Public Safety, Emergency Response and Disaster Recovery

The above example paints the picture of a Municipal Wi-Fi network in a city. However many of the same deployment methods also apply to public safety, emergency response and disaster recovery with the following differences –

1. Proxim ORiNOCO AP-4900MR-LR units operating in the 4.9GHz band would be deployed in the key city areas instead of the AP-4000MR-LR

Fig 1.5 Schematic of Deployed System

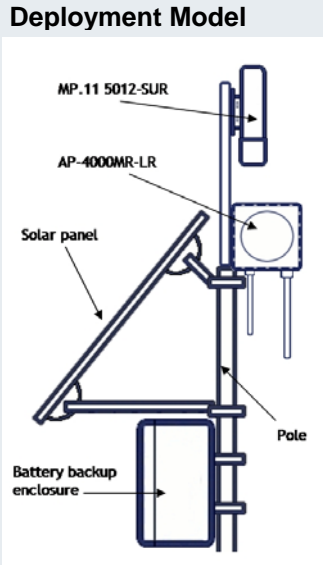

This deployment utilizes Proxim's outdoor ORiNOCO AP-4000MR-LR, and for the dual installs an ORiNOCO AP-4000MR-LR and a Tsunami MP.11 5012-SUR outdoor unit.

Each uses a direct DC connection DC/DC converter, so a 10% inefficiency factor is added for this conversion.

Being all in one units the outdoor AP-4000MR-LR and MP.11 5012-SUR reduces the amount of cable to be run.



Source: sunwize.com

2. Wi-Fi may not be used and can be turned on or off depending on need
3. Proxim ORiNOCO AP-4900M mesh units mounted in vehicles allow them to connect to the mesh network on the fly
4. All in one portable units with a mesh AP and solar power system are ideal for quick temporary deployments to other locations in emergencies
5. Such portable units would also be vital in setting up temporary networks during disaster recovery situations

Portable power in emergency situations is critical. Solar power provides continuous power for wireless communication equipment without the need to be refueled.

Department of Transportation

In most places the roads are maintained by a government agency, e.g., Department of Transportation whose responsibilities include road repair and maintenance, repair and maintenance of signs and roadside

devices as well as assistance in the case of disabled vehicles. Portable power plays a role here in many ways and the inclusion of wireless communication tools such as mesh APs can have many applications. In the case of our municipal deployment example, additional transportation related uses are –

1. Like other roadside devices using solar power, mesh AP's and Tsunami MP.11 subscriber units can be deployed on poles -enabling network access
2. Interstate highways can be lit up in this fashion allowing network access where it was non-existent prior
3. All in one portable units with a mesh AP and solar power system can be made for temporary deployments for road crews or satellite construction offices

The ability to deploy wireless equipment where it was not possible before brings with it the possibility of unprecedented levels of communications and data access.

Solar Powered Wireless Networks Avoid Hidden Costs

There are a lot of hidden costs associated with using traditional power when deploying an outdoor broadband wireless network that Solar Power can overcome.

1. When using utility poles the power companies call the shots and can charge a number of one time or reoccurring fees

- c. Pole permits, usually one time fee from \$25 and up per attachment
- d. Attachment fees, usually goes by the foot occupied and can range from \$6-\$10 per foot per month per pole
- e. Infrastructure fees, usually \$6-\$10 per month per device whether you use the power or not
- f. Meter fees, if the power company decides to install a meter there may be a reoccurring cost associated with that
- g. Any other fees the power company may decide upon—after all you are using their property and power

2. Rooftop use, while the deal will depend upon the owner of the roof, again they call the shots when it comes to using power

- a. Depending on the deal you may get a free ride for providing free access, or you could get charged rental fees plus fees for power use
- b. If rental fees are present they will be unavoidable, but with solar power you can avoid any extra fees for power use, egress point use, etc.

3. Sometimes you have to install in a location that either does not have any power run to it, or has existing timed devices such as lights that will need to be re-wired.

- a. Costs for running power, or rewiring can be very expensive and depend on local rates. It could be from \$2,000 and up for each instance

Mobility and Rapid Re-deployment

Not being tethered to the power grid:

1. Sites can be taken down and put up at new locations without worrying with disconnecting any lines
2. Custom structures with no power drawn can be used
 - a. If no pole exists, one can be installed
 - b. Unconventional structures could be used, even trees

3. Excellent opportunities for transportation departments and public safety

- a. Road crews can make use of mobile Mesh units similar to the mobile electronic signs to exchange data
- b. Mobile Mesh units will be critical in public safety emergencies and disaster recovery

Considerations for Maintenance

When comparing Solar power versus traditional power there are several compelling items to take note of:

1. High quality solar panels can have a warrantee lifespan of up to 25 years
2. High quality solar battery backup systems can last up to 10 years





3. Incidental maintenance for equipment damage carries different costs between solar and traditional power

- a. Utilities generally require the use of certified linemen when working with anything on their poles. Charges for a line crew and bucket truck can reach to \$250 per hour
- b. Solar equipment not connected to the infrastructure does not require this allowing you to utilize less expensive labor

4. When connected to the traditional power infrastructure you are subject to any power outages and downtime that the utility experiences. Solar can provide in excess of 99.999% uptime

5. Solar power means that the equipment will continue to operate even during local or city-wide power outages

6. A solar powered system may run for up to 10 days or more without sun!

Despite a higher initial cost when deploying with solar power, the reduced maintenance costs combined with the flexibility to install anywhere allows you to use this type of network for a variety of needs as well as get around obstacles encountered when traditional power is used.

The addition of the ProximVision™ network management appliance will allow you to centrally control the entire network, driving down management costs.

Conclusions

Solar power is both a benefit and a necessity in many areas

- No emissions making it environmentally safe
- No re-occurring energy costs
- Power where no traditional power exists
- Portability and rapid deployment
- Flexibility to install nearly anywhere
- Backup even when the traditional electrical grid maybe down for days
- Solar Powered systems offer a collateral benefit of a system that operates when all else has failed

Low power consumption is critical

- Reduces the size of the solar power system required
- Helps maintain availability and reliability
- Reduces your initial costs maximizing your ROI

Proxim Wireless broadband products are the best fit for solar power systems

- Proxim's mesh and WiMAX products have the lowest power consumption in the industry
- Small form factor radios allow for rapid deployment and redeployment
- Public safety solutions to take advantage of the flexibility and portability
- Management costs minimized with ProximVision
- Go green and install where you want with a truly wire-free Outdoor Wireless Broadband network!



NETWORKWORLD



“We firmly believe that Proxim's contributions to the wireless broadband market with respect to WiMAX far exceed that of any other player in the market today and therefore will be a major driver for the deployment of WiMAX as the market develops.”

*Sivakumar Muthuramalingam
Research Analyst Frost & Sullivan*

Proxim Wireless Corporation is a wholly owned subsidiary of Terabeam, Inc. (NASDAQ: TRBM). Proxim Wireless is a global pioneer in developing and supplying scalable broadband wireless networking systems for enterprises, governments, and service providers. From Wi-Fi to wireless Gigabit Ethernet – our WLAN, mesh, point-to-multipoint, and point-to-point products are available through our extensive global channel network, backed by world-class support. Proxim is a Principal Member of the WiMAX Forum and is ISO-9001 certified. Information about Proxim and its products and support can be found at: www.proxim.com.